

Adjustable Stainless Steel- Hand levers

Electropolished, with bushing / with threaded stud

SPECIFICATION

Types

- Type **AS**: with external hexagon
- Type **IS**: with internal hexalobular

Handle
Stainless Steel
Precision casting

- Stainless Steel AISI CF-8
- electropolished

Version with bushing

Bushing
Stainless Steel AISI 303

Retaining screw
Stainless Steel AISI 303

Spring
Stainless Steel AISI 301

Version with threaded stud

Threaded stud
Stainless Steel AISI 303

Retaining screw
Stainless Steel AISI 303

Spring
Stainless Steel AISI 301

INFORMATION

Adjustable hand levers GN 300.6 with full Stainless Steel-Handle, correspond to applications where „agressive“ surrounding conditions are given, or where stainless steel materials are prescribed such as in food processing or chemical industry.

Retaining screws with hexagon head (Type AS) comply with the requirement "prevents water from accumulating".

Adjustable hand levers have proved to be ideal whenever parts have to be clamped in a confined space or in a particular lever position. The centre insert is connected to the lever via serrations which can easily be disengaged.

Pulling the lever, disengages the serrations and allowing it to be swivelled to the ideal clamping position. On releasing the lever the

* Complete with types of the Hand levers (AS or IS)

AS External hexagon
IS Internal hexagon



TECHNICAL INFORMATION

- ISO-Fundamental tolerances (see page A21)
- Stainless Steel characteristics (see page A26)

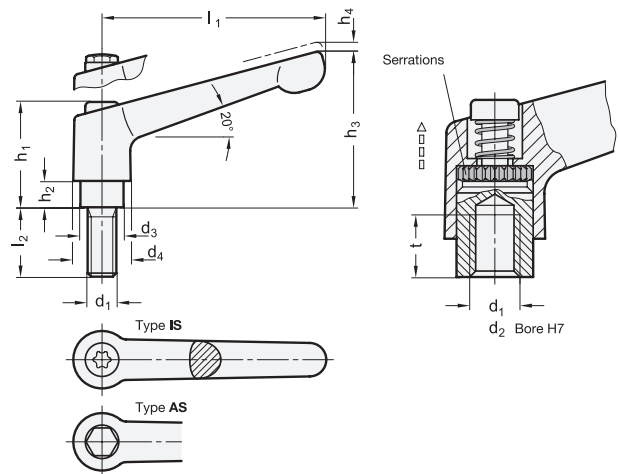

GN 300.6-with bushing

STAINLESS STEEL

Description	l1	d1	d2 H7	d3	d4	h1	h2	h3	h4	t min.	ΔΔ
GN 300.6-30-B5-*	30	-	B 5	10	13	24.5	4	31	3.5	8	27
GN 300.6-30-B6-*	30	-	B 6	10	13	24.5	4	31	3.5	8	28
GN 300.6-30-M3-*	30	M 3	-	10	13	24.5	4	31	3.5	7	25
GN 300.6-30-M4-*	30	M 4	-	10	13	24.5	4	31	3.5	8	31
GN 300.6-30-M5-*	30	M 5	-	10	13	24.5	4	31	3.5	8	29
GN 300.6-30-M6-*	30	M 6	-	10	13	24.5	4	31	3.5	8	30
GN 300.6-45-B5-*	45	-	B 5	10	13	24.5	4	34	3.5	8	35
GN 300.6-45-B6-*	45	-	B 6	10	13	24.5	4	34	3.5	8	36
GN 300.6-45-M4-*	45	M 4	-	10	13	24.5	4	34	3.5	8	44
GN 300.6-45-M5-*	45	M 5	-	10	13	24.5	4	34	3.5	8	40
GN 300.6-45-M6-*	45	M 6	-	10	13	24.5	4	34	3.5	8	39

GN 300.6-with threaded insert

STAINLESS STEEL

Description	l1	d1	d2 H7	d3	d4	h1	h2	h3	h4	t min.	ΔΔ
GN 300.6-63-B8-*	63	-	B 8	13.5	17.5	31	6.5	45	4	11	86
GN 300.6-63-M6-*	63	M 6	-	13.5	17.5	31	6.5	45	4	11	85
GN 300.6-63-M8-*	63	M 8	-	13.5	17.5	31	6.5	45	4	11	84
GN 300.6-78-M8-*	78	-	B 8	16	21	36	8	54	4	14	140
GN 300.6-78-M10-*	78	-	B 10	16	21	36	8	54	4	14	138
GN 300.6-78-M8-*	78	M 8	-	16	21	36	8	54	4	14	137
GN 300.6-78-M10-*	78	M 10	-	16	21	36	8	54	4	14	135
GN 300.6-78-M12-*	78	M 12	-	16	21	36	8	54	4	14	132
GN 300.6-92-M10-*	92	-	B 12	19	24	43	11	64	4	17	220
GN 300.6-92-M10-*	92	M 10	-	19	24	43	11	64	4	17	218
GN 300.6-92-M12-*	92	M 12	-	19	24	43	11	64	4	17	216

Weight type AS

* Complete with types of the Hand levers (AS or IS)

AS External hexagon
IS Internal hexagon

GN 300.6-with threaded stud

STAINLESS STEEL

Description	l1	d1	l2	d3	d4	h1	h2	h3	h4	Δ
GN 300.6-30-M3-6-*	30	M 3	6	10	13	24.5	4	31	3.5	28
GN 300.6-30-M3-8-*	30	M 3	8	10	13	24.5	4	31	3.5	29
GN 300.6-30-M3-10-*	30	M 3	10	10	13	24.5	4	31	3.5	30
GN 300.6-30-M3-12-*	30	M 3	12	10	13	24.5	4	31	3.5	31
GN 300.6-30-M3-16-*	30	M 3	16	10	13	24.5	4	31	3.5	32
GN 300.6-30-M4-12-*	30	M 4	12	10	13	24.5	4	31	3.5	32
GN 300.6-30-M4-16-*	30	M 4	16	10	13	24.5	4	31	3.5	33
GN 300.6-30-M4-20-*	30	M 4	20	10	13	24.5	4	31	3.5	34
GN 300.6-30-M4-25-*	30	M 4	25	10	13	24.5	4	31	3.5	35
GN 300.6-30-M4-32-*	30	M 4	32	10	13	24.5	4	31	3.5	36
GN 300.6-30-M5-12-*	30	M 5	12	10	13	24.5	4	31	3.5	32
GN 300.6-30-M5-16-*	30	M 5	16	10	13	24.5	4	31	3.5	33
GN 300.6-30-M5-20-*	30	M 5	20	10	13	24.5	4	31	3.5	33
GN 300.6-30-M5-25-*	30	M 5	25	10	13	24.5	4	31	3.5	34
GN 300.6-30-M5-32-*	30	M 5	32	10	13	24.5	4	31	3.5	35
GN 300.6-30-M5-40-*	30	M 5	40	10	13	24.5	4	31	3.5	36
GN 300.6-30-M5-50-*	30	M 5	50	10	13	24.5	4	31	3.5	37
GN 300.6-30-M6-12-*	30	M 6	12	10	13	24.5	4	31	3.5	33
GN 300.6-30-M6-16-*	30	M 6	16	10	13	24.5	4	31	3.5	34
GN 300.6-30-M6-20-*	30	M 6	20	10	13	24.5	4	31	3.5	335
GN 300.6-30-M6-25-*	30	M 6	25	10	13	24.5	4	31	3.5	35
GN 300.6-30-M6-32-*	30	M 6	32	10	13	24.5	4	31	3.5	40
GN 300.6-30-M6-40-*	30	M 6	40	10	13	24.5	4	31	3.5	42
GN 300.6-30-M6-50-*	30	M 6	50	10	13	24.5	4	31	3.5	43
GN 300.6-45-M4-12-*	45	M 4	12	10	13	24.5	4	34	3.5	43
GN 300.6-45-M4-16-*	45	M 4	16	10	13	24.5	4	34	3.5	44
GN 300.6-45-M4-20-*	45	M 4	20	10	13	24.5	4	34	3.5	42
GN 300.6-45-M4-25-*	45	M 4	25	10	13	24.5	4	34	3.5	43
GN 300.6-45-M4-32-*	45	M 4	32	10	13	24.5	4	34	3.5	44
GN 300.6-45-M5-12-*	45	M 5	12	10	13	24.5	4	34	3.5	40
GN 300.6-45-M5-16-*	45	M 5	16	10	13	24.5	4	34	3.5	41
GN 300.6-45-M5-20-*	45	M 5	20	10	13	24.5	4	34	3.5	42
GN 300.6-45-M5-25-*	45	M 5	25	10	13	24.5	4	34	3.5	44
GN 300.6-45-M5-32-*	45	M 5	32	10	13	24.5	4	34	3.5	45
GN 300.6-45-M5-40-*	45	M 5	40	10	13	24.5	4	34	3.5	47
GN 300.6-45-M5-50-*	45	M 5	50	10	13	24.5	4	34	3.5	48
GN 300.6-45-M6-12-*	45	M 6	12	10	13	24.5	4	34	3.5	40
GN 300.6-45-M6-16-*	45	M 6	16	10	13	24.5	4	34	3.5	41
GN 300.6-45-M6-20-*	45	M 6	20	10	13	24.5	4	34	3.5	43
GN 300.6-45-M6-25-*	45	M 6	25	10	13	24.5	4	34	3.5	44
GN 300.6-45-M6-32-*	45	M 6	32	10	13	24.5	4	34	3.5	45
GN 300.6-45-M6-40-*	45	M 6	40	10	13	24.5	4	34	3.5	46
GN 300.6-45-M6-50-*	45	M 6	50	10	13	24.5	4	34	3.5	50
GN 300.6-63-M6-16-*	63	M 6	16	13.5	17.5	31	6.5	45	4	73
GN 300.6-63-M6-20-*	63	M 6	20	13.5	17.5	31	6.5	45	4	80
GN 300.6-63-M6-25-*	63	M 6	25	13.5	17.5	31	6.5	45	4	90
GN 300.6-63-M6-32-*	63	M 6	32	13.5	17.5	31	6.5	45	4	100

GN 300.6-with threaded stud

STAINLESS STEEL

Description	l1	d1	l2	d3	d4	h1	h2	h3	h4	Δ
GN 300.6-63-M6-40-*	63	M 6	40	13.5	17.5	31	6.5	45	4	102
GN 300.6-63-M6-50-*	63	M 6	50	13.5	17.5	31	6.5	45	4	105
GN 300.6-63-M6-63-*	63	M 6	63	13.5	17.5	31	6.5	45	4	106
GN 300.6-63-M8-16-*	63	M 8	16	13.5	17.5	31	6.5	45	4	108
GN 300.6-63-M8-20-*	63	M 8	20	13.5	17.5	31	6.5	45	4	109
GN 300.6-63-M8-25-*	63	M 8	25	13.5	17.5	31	6.5	45	4	110
GN 300.6-63-M8-32-*	63	M 8	32	13.5	17.5	31	6.5	45	4	112
GN 300.6-63-M8-40-*	63	M 8	40	13.5	17.5	31	6.5	45	4	114
GN 300.6-63-M8-50-*	63	M 8	50	13.5	17.5	31	6.5	45	4	116
GN 300.6-63-M8-63-*	63	M 8	63	13.5	17.5	31	6.5	45	4	118
GN 300.6-78-M8-20-*	78	M 8	20	16	21	36	8	54	4	130
GN 300.6-78-M8-25-*	78	M 8	25	16	21	36	8	54	4	140
GN 300.6-78-M8-32-*	78	M 8	32	16	21	36	8	54	4	150
GN 300.6-78-M8-40-*	78	M 8	40	16	21	36	8	54	4	155
GN 300.6-78-M8-50-*	78	M 8	50	16	21	36	8	54	4	168
GN 300.6-78-M8-63-*	78	M 8	63	16	21	36	8	54	4	173
GN 300.6-78-M10-63-*	78	M 10	63	16	21	36	8	54	4	176
GN 300.6-78-M10-20-*	78	M 10	20	16	21	36	8	54	4	160
GN 300.6-78-M10-25-*	78	M 10	25	16	21	36	8	54	4	165
GN 300.6-78-M10-32-*	78	M 10	32	16	21	36	8	54	4	170
GN 300.6-78-M10-40-*	78	M 10	40	16	21	36	8	54	4	175
GN 300.6-78-M10-50-*	78	M 10	50	16	21	36	8	54	4	180
GN 300.6-78-M10-63-*	78	M 10	63	16	21	36	8	54	4	182
GN 300.6-78-M10-80-*	78	M 10	80	16	21	36	8	54	4	185
GN 300.6-78-M12-20-*	78	M 12	20	16	21	36	8	54	4	165
GN 300.6-78-M12-25-*	78	M 12	25	16	21	36	8	54	4	168
GN 300.6-78-M12-32-*	78	M 12	32	16	21	36	8	54	4	174
GN 300.6-78-M12-40-*	78	M 12	40	16	21	36	8	54	4	180
GN 300.6-78-M12-50-*	78	M 12	50	16	21	36	8	54	4	189
GN 300.6-78-M12-63-*	78	M 12	63	16	21	36	8	54	4	195
GN 300.6-78-M12-80-*	78	M 12	80	16	21	36	8	54	4	207
GN 300.6-92-M10-20-*	92	M 10	20	19	24	43	11	64	4	214
GN 300.6-92-M10-25-*	92	M 10	25	19	24	43	11	64	4	230
GN 300.6-92-M10-32-*	92	M 10	32	19	24	43	11	64	4	240
GN 300.6-92-M10-40-*	92	M 10	40	19	24	43	11	64	4	260
GN 300.6-92-M10-50-*	92	M 10	50	19	24	43	11	64	4	270
GN 300.6-92-M10-63-*	92	M 10	63	19	24	43	11	64	4	275
GN 300.6-92-M10-80-*	92	M 10	80	19	24	43	11	64	4	248
GN 300.6-92-M12-20-*	92	M 12	20	19	24	43	11	64	4	250
GN 300.6-92-M12-25-*	92	M 12	25	19	24	43	11	64	4	252
GN 300.6-92-M12-32-*	92	M 12	32	19	24	43	11	64	4	250
GN 300.6-92-M12-40-*	92	M 12	40	19	24	43	11	64	4	260
GN 300.6-92-M12-50-*	92	M 12	50	19	24	43	11	64	4	265
GN 300.6-92-M12-63-*	92	M 12	63	19	24	43	11	64	4	270
GN 300.6-92-M12-80-*	92	M 12	80	19	24	43	11	64	4	295

Weight type AS



Clamping levers